

# IMPORTANT SAFETY INSTRUCTIONS

## CAUTION

Operators must read and understand this manual before operating or maintaining this equipment.

- Keep hands and feet clear of moving parts while machine is in operation.
- All switches must be in the “OFF” position when charging batteries.
- Electrical motors and components can cause an explosion when operated near explosive materials or vapors. Do not operate this machine near flammable materials such as solvents, thinners, fuels, grain dusts, etc.
- Make sure all switches are turned “OFF” and battery connections are removed before performing any maintenance procedures.
- Store or park this machine on a level surface only.
- These machines are designed for level floor operation only. DO NOT OPERATE on ramps or inclines.
- Battery acid can cause burns. When working on or around batteries, wear protective clothing and safety glasses. Remove metal jewelry. Do not lay tools or metal objects on top of batteries.
- This machine is not suitable for picking up hazardous dust.

Charging batteries generates explosive gases. DO NOT CHARGE BATTERIES WHEN OPEN FLAMES OR SPARKS ARE PRESENT. DO NOT SMOKE. Make sure the charger is turned off before disconnecting it from the batteries. Charge the batteries in a well-ventilated area.

Maintenance and repairs must be performed by authorized personnel.

**SAVE THESE INSTRUCTIONS**

## ELECTRICAL REQUIREMENTS:

This piece of equipment operates on 36 Volt DC.

## BATTERY REQUIREMENTS:

6 x 6V 220AH P/N 956720

6 x 6V 275AH P/N 956740

## BATTERY SERVICE AND INSTALLATION:

\* Warning: Battery acid can cause burns. When working on or around batteries, wear protective clothing and safety glasses. Remove metal jewelry. Do not lay tools or metal objects on top of batteries.

## BATTERY INSTALLATION:

1. Raise tank assembly by raising rear cover and disconnecting vacuum recovery hose, Figure 1.
2. Tilt recovery tank.
3. Install batteries as shown in figure 2.

## CHARGING OF BATTERIES:

Charging of batteries generates explosive gases. DO NOT CHARGE BATTERIES WHEN OPEN FLAMES OR SPARKS ARE PRESENT. DO NOT SMOKE. Make sure the charger is turned off before disconnecting it from the batteries. Charge the batteries in a well-ventilated area. Fluid levels should be checked before and after charging and maintained at the proper levels.

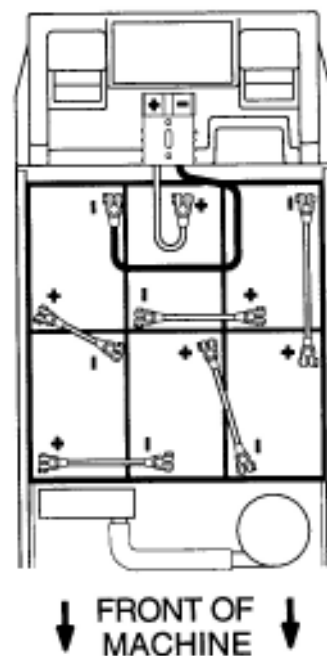
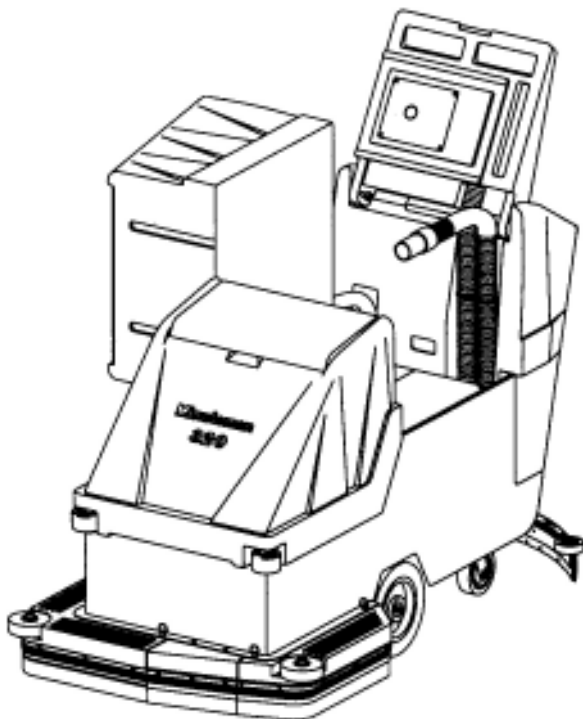

# CONTROL PANEL IDENTIFICATION

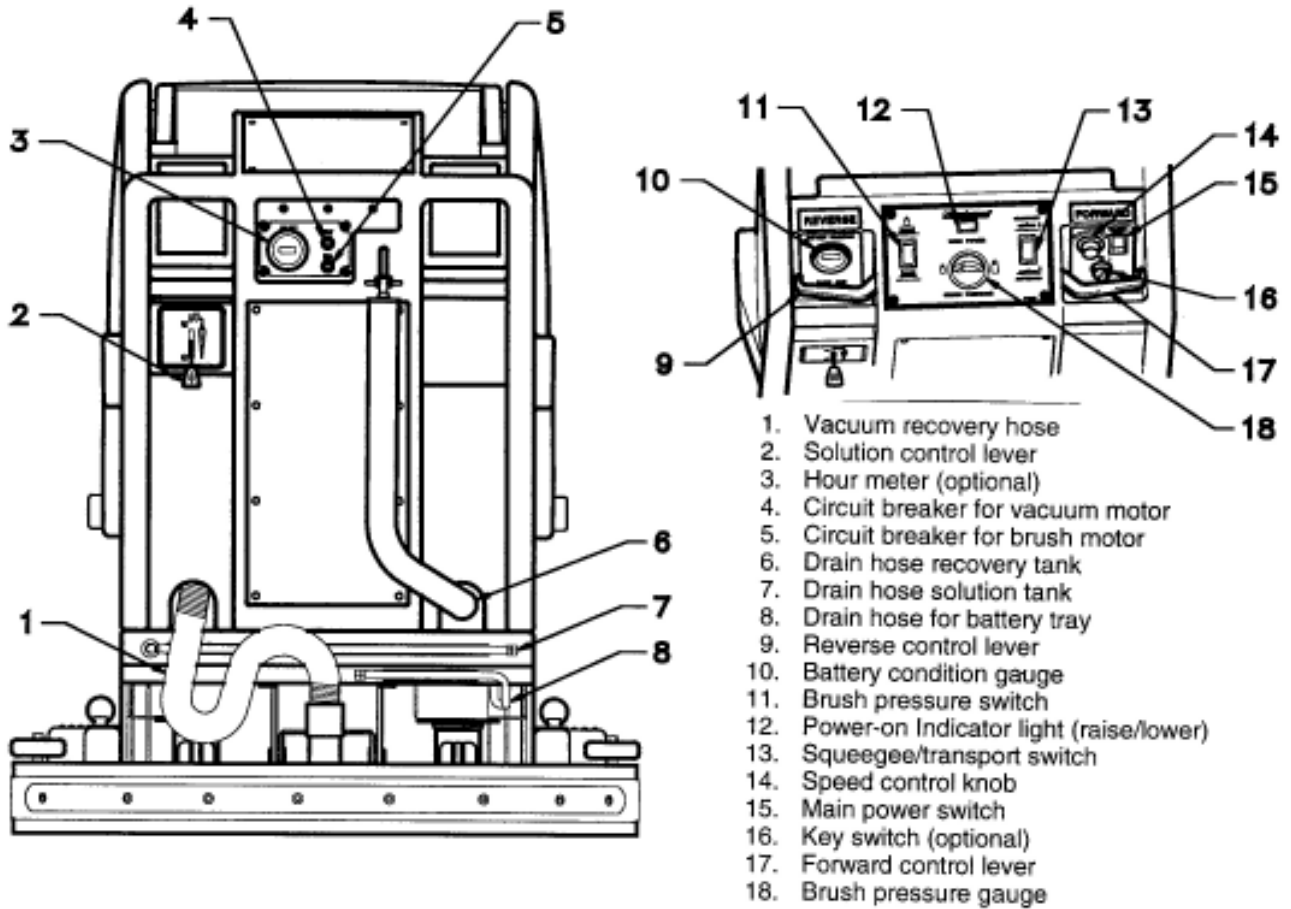

## AUTO SCRUBBER BRUSH DESCRIPTION

TYPE	DESCRIPTION	DURABILITY*	COLOR	COMPARISON TO PADS	RECOMMENDED USE
Bassine	Natural Fiber	Short	DarkBrown	Red	Light duty general cleaning, acid etching
Nylon	Nylon	Medium	Black	Tan/Red	General cleaning & scrubbing vinyl floors, ceramic tile & concrete floors
Dyna-Scrub	Nylon impregnated with 500 Grit Silicon Carbide Fine Bristle, Dense Fill	Long	Light Blue	Red	General scrubbing, vinyl tile, ceramic tile, epoxy floors, urethane finish, uneven concrete floors
Power-Scrub	Nylon impregnated with 120 Grit Silicon Carbide Fine Bristle, Dense Fill	Long	Rust	Red/Blue	Moderate aggressive scrubbing, tile floors concrete floors
Poly-Grit	Nylon impregnated with 80 Grit Silicon Carbide Coarse Bristle	Long	Green	Brown/Black	Aggressive stripping and scrubbing, tile floors, unfinished concrete floors
Strata-Grit	Nylon impregnated with 46 Grit Silicon Carbide Coarse Bristle	Long	Dark Blue	Black	Heavy duty stripping/scrubbing unfinished concrete

\* Durability is dependent on floor surface, chemicals used and proper care.

# SQUEEGEE ADJUSTMENTS

## Squeegee Adjustment

The squeegee set-up is pre-adjusted at the factory. Adjustments may be required to get optimum performance for different floors and conditions.

## Pitch Control Adjustment

1. Ensure that the scrubber is on a relatively flat surface. Turn on the main power switch and raise the scrubhead assembly off the floor. Set the squeegee/vacuum switch to the automatic mode.
2. Turn the speed control knob counter-clockwise to the low speed position. Squeeze the forward control lever to lower the squeegee (item 1) to the floor. Move the machine one or two feet forward. To check the rear squeegee blade for uniform deflection to the floor.
3. If uneven deflection or lay is evident, minor adjustments may be necessary to avoid streaking and uneven wear on the blade.
4. To correct this, pitch adjustment is necessary. Loosen the pivot screw (item 2) and the pitch screw (item 3). Move the machine forward and allow the squeegee to level itself or adjust the angular position accordingly to achieve a uniform blade deflection. Re-tighten screws.
5. In certain applications where a different blade set-up is required, the reinforcement blade (item 4) may be turned upside down. The notch, which is normally on the bottom will now be located on the top side. This adjustment allows the rear squeegee blade a larger deflection than normal.

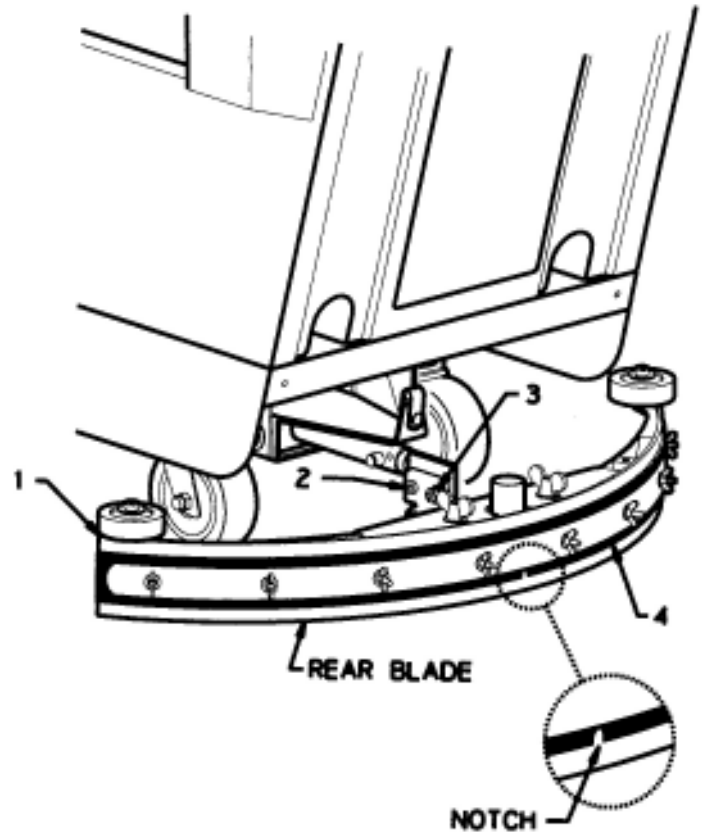

# OPERATING INSTRUCTIONS

1. Filling: Fill the solution tank with the desired amount of water and add liquid cleaning solution to the proper dilution ratio. **DO NOT USE** powdered cleaning chemicals. Powders are unlikely to dissolve thoroughly, resulting in clogging the in-line solution filter. This can reduce or stop water flow to the brush.
2. Close lid.
3. Turn on main power switch (Refer to Page 3 #16).
4. Adjust main speed control #15 to full counter-clockwise position.
5. Lower brush assembly (ref. page 3 #12) using switch. Brushes will not come on until forward #18 or reverse #10 lever are pulled. Brushes will remain on for 3 to 5 seconds after levers are released. Adjustments to brush pressure can be made by depressing switch #12 and reading brush pressure gauge #19.
6. Squeegee Control/Vacuum.  
Switch #14 has two positions one is for **transport**/double scrubbing, when the switch is in this position the squeegee will raise and the vacuum will turn off. With the switch in **automatic** mode the squeegee will automatically lower in forward movement of the machine and vacuum will turn on. When the machine is reversed the squeegee will automatically raise and the vacuum motor will turn off.
7. Solution Control #2.  
The solution lever is a mechanical cable that opens the solution valve. This lever must be moved to the full on position then decrease to desired flow to operate properly.

## AUTOMATIC PARKING BRAKE OPERATION:

Brake lever located behind left wheel.

**Run Mode** - Normal operation; Brake lever in down position.

- When the power is turned off the brake is automatically engaged.
- When the power is turned on the brake is automatically disengaged and the drive system is enabled.

**Push Mode** - Machine inoperable; Brake lever in up position.

- Brake is manually disengaged.
- Power is shut off to the drive system.

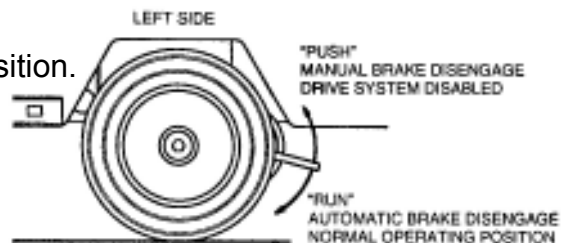

## MAINTENANCE:

- |         |   |
|---------|---|
| Daily   | <ol style="list-style-type: none"><li>1. Clean float assembly &amp; squeegee blades. Vac filter.</li><li>2. Recharge batteries (check battery acid levels before and after charging).</li></ol> |
| Monthly | <ol style="list-style-type: none"><li>1. Check wear on squeegee blades.</li><li>2. Grease rear wheels.</li><li>3. Grease pivot points on brush motor assembly.</li></ol>                        |

# MAINTENANCE OF MACHINE

## VACUUM MOTOR

Motor brushes can be replaced with Brush Set, Part No. 741008. Brushes should be replaced only once. More than once brush replacement will cause very high current consumption. This undue current consumption lowers overall machine performance and is not in the best interest of economical machine use.

## CARBON BRUSHES IN DRIVE MOTOR

Inspect these brushes once every 18 months or 720 hours.

The brushes can now be inspected by removing the brush caps near the end of the drive motor. Examine all four brush lengths; if the back end of a brush is even with the edge of the brush holder or shorter, the brush must be replaced. Replace with Brush Set, Part No. 744155. When installing new brushes, also inspect commutator for pits and/or excessive wear. If it is in poor condition, replace drive motor with Part No. 744154.

## CARBON BRUSHES IN BRUSH DRIVE MOTORS

Inspect these brushes once every six months or 360 hours.

Remove scrubhead assembly. Then remove the air vent ring on each motor and examine brush lengths; if the back end of brush is even with the edge of the brush holder or shorter, the brush must be replaced. Replace with Part No. 833474. When installing new brushes, also inspect commutator for pits and/or excessive wear. Replace motor with Part No. 833379 if commutator is in poor condition.

## LUBRICATION

1. Grease casters once every week (two fittings per caster) or 15 hours.
2. Oil all moving parts such as hinges and pressure points once every month or every 60 hours.

## SQUEEGEE RUBBERS

When the thick rear squeegee rubber is damaged or worn excessively, it will cause streaking and poor solution pickup. Extended rubber life can be obtained by reversing it, provided it is not torn or otherwise damaged. Do not tighten screws so tightly that squeegee rubbers are made to bulge and show an uneven edge.

## TANKS

At the end of a day's work (or work cycle, both the vacuum and solution tanks should be drained and flushed with warm water.

Once a week for 15 hours the vacuum tank should be cleaned of settled debris. This can be done by lowering the drain hose and washing out the debris.

## BATTERIES (956720, 956740)

Periodically remove batteries from machine. Clean batteries, battery tray, and battery compartment with a solution of baking soda and water. Check all battery cables and wiring for signs of damage or wear. Replace as needed. Check battery fluid level each charge. Check electrolyte with hydrometer every 15 hours.

# TROUBLE SHOOTING

1. Inefficient scrubbing - floors are smeared in appearance.

Solution: Use proper type and correct amount of detergent. Replace worn or damaged scrub attachments. Increase force on scrubbing head.

2. Squeegee streaks.

Solution: Check rear squeegee rubber for imbedded objects, clean; reverse, or replace if worn or damaged. Make sure scrub solution is being fed onto brush properly. Use more scrubbing solution. Replace well-worn scrubber attachments.

3. Odor development.

Solution: Inspect and clean thoroughly the vacuum tank, solution tank, squeegee, vacuum motor, vacuum hose. NOTE: Super Staph-Trole 64 disinfectant cleaner can be helpful in reducing odors.

4. Vacuum not picking up.

Solution: Water lift should be 60-65" with fully charged batteries. Check seals around vacuum motor and hose connections. Check vacuum tank drain hose and plug to insure seal. Check hoses for holes. Clean out squeegee inlet and check squeegee rubbers for severe wear. Make sure solution is properly feeding into scrubhead attachments. Clean and/or repair vacuum motor.

5. Charger malfunction.

Solution: Consult maintenance and repair data contained in brochure herewith for detailed information. In general, make sure charger is put in upright position when charging - this helps keep unit cool. Do not cover charger when it is in use. Make sure connectors on inlet and outlet cords are not broken. Check AC input voltage - it should be 110 volts, 120 volts, maximum. Replace faulty fuses, ammeter, timer, or other components, when necessary.

6. Use cycle too short.

Solution: Check voltage on batteries after full charging; output voltage should be 43-45 volts with specific gravity at 1.260-1.265. Check battery electrolyte level. Check for loose or corroded battery leads and connections. Replace batteries that will not hold a charge. Lubricate casters. Reduce scrubbing pressure. Check brushes on motors, especially on vacuum motor. Replace brushes on motors when needed. Test charger for output, it may need repair.

7. Motors will not start or run.

Solution: Check battery leads and connection for corrosion and looseness; correct if required. Check switches for proper contacting; replace if required. Check motor brushes; replace brushes or motors if required.

8. Speed control does not function.

Solution: The speed control has built-in protection to guard against reversed connections, check battery connections. Machine locked in high or low speed. Inspect entire speed control for burn marks of components that have broken. These would be caused by a direct short in the circuit. Replace entire control as needed.

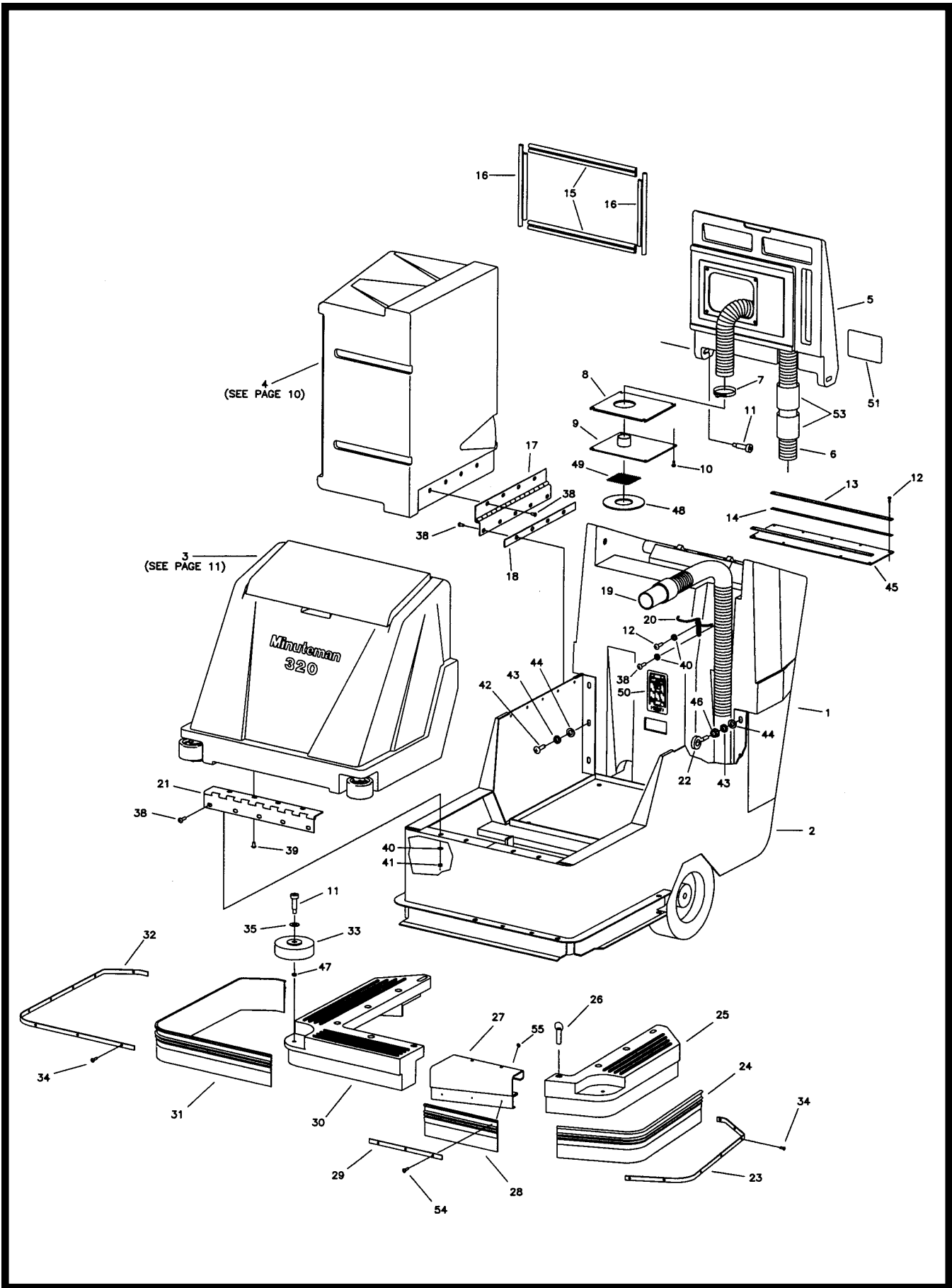



# Parts List

Item	Part No.	Qty.	Description
1	320122	1	Console 320 Char Grey
2	320700	1	Mainframe Minuteman 320
3	320300	1	Solution Tank Assembly
4	320200	1	Recovery Tank Assembly
5	320146B	1	Recovery Lid 320 Burgundy
6	320220	1	Vacuum Hose Assy.
7	260203	1	Hose Clamp
8	320222	1	Gasket
9	320178	1	Water Shut-Off Plate
10	712540	6	SCR-MC 10-24 x .37 SS TH
11	712102	4	Bolt-Shoulder 1/2 x 1.50
12	711161	11	SCR-HI/LO 10 x 5/8
13	260170	2	Retainer Flap
14	760263	2	Foam Tape 16.50"
15	320239	2	Lid Gasket Long
16	260157	2	Lid Gasket Short
17	320145	1	Recovery Tank Hinge
18	320144	1	Backing Strap
19	450090	1	Recovery Hose Assembly
20	320208	1	Retaining Hook
21	260087	1	Hinge
22	712086	1	5/16 Wire Eyebolt
23	320224	1	Skirt Retainer - Left Side
24	320231	1	Rubber Skirt - Left Side
25	320124	1	Plastic Skirt - Left Side
26	320234	4	Skirt Pin
27	320235	1	Center Skirt Weldment
28	320232	1	Rubber Skirt - Center
29	320227	1	Skirt Retainer - Center
30	320123	1	Plastic Skirt - Right Side
31	320230	1	Rubber Skirt - Right Side
32	320223	1	Skirt Retainer - Right Side
33	320013	2	Wheel, Bumper 4 x 1 1/2
34	711106	15	SCR-ST-A 10 x .75 PL
35	711592	2	WSR-Nylon .5 x 1.06 x .06
36			
37			
38	712565	20	SCR-MC 1/4-20 x .75 SS
39			
40	711504	6	WRS-Flat 1/4 SS
41	712667	4	Nut-Nyloc 1/4-20
42	710196	5	SCR-MC 5/16 - 18 x .75 STPL
43	711545	6	WSR-Helical 5/16
44	711506	6	WSR-Flat 5/16 ST PL
45	320244	1	Lid Flap
46	711379	1	Nut-Flanged Wizz 5/16 - 18
47	832015	2	Spacer .38 x .50 x .14
48	260294	1	Gasket 2.0 x 4.0 x .125
49	807051	1	Screen Filter 4.0 x 4.0
50	715628	1	Battery Decal
51	715619	1	Warning Decal
52			
53	260192	2	Sleeve
54	712536	3	SCR-MC 10-24 x .62 SS
55	712638	3	Nut Hex 10-24 SS Nyloc

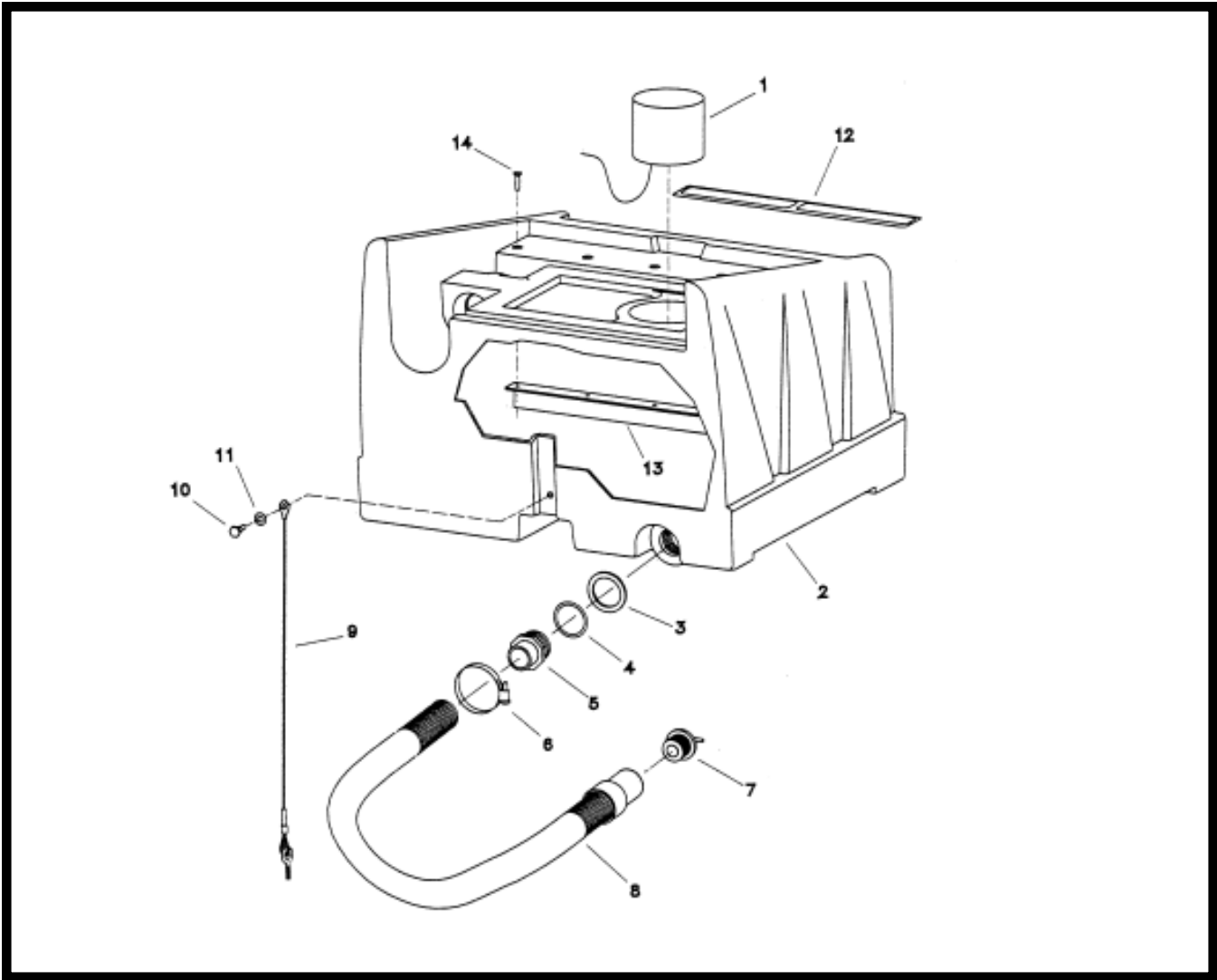

**320200**  
**RECOVERY TANK ASSEMBLY**

Item	Part No.	Qty.	Description
1	260156	1	Foam Float Assembly
2	320121	1	Recovery Tank
3	828970	1	WSR-Neop 1.81 x 2.37
4	450081	1	WSR-SS 1.908 x 2.41 x .03
5	760220MCH	1	1.5 Adaptor Gray
6	260203	1	Hose Clamp Wire Grip
7	833316	1	Drain Plug 1 1/4
8	260202	1	Drain Hose Assembly
9	320206	1	Recovery Tank Cable
10	712575	1	5/16-18 x .75 HH SS
11	711506	1	WSR-Flat 5/16
12	715620	1	Decal "Maintenance Schedule"
13	320009	1	Backing Angle
14	712563	5	SCR-MC 1/4-20 x 1.00 FH

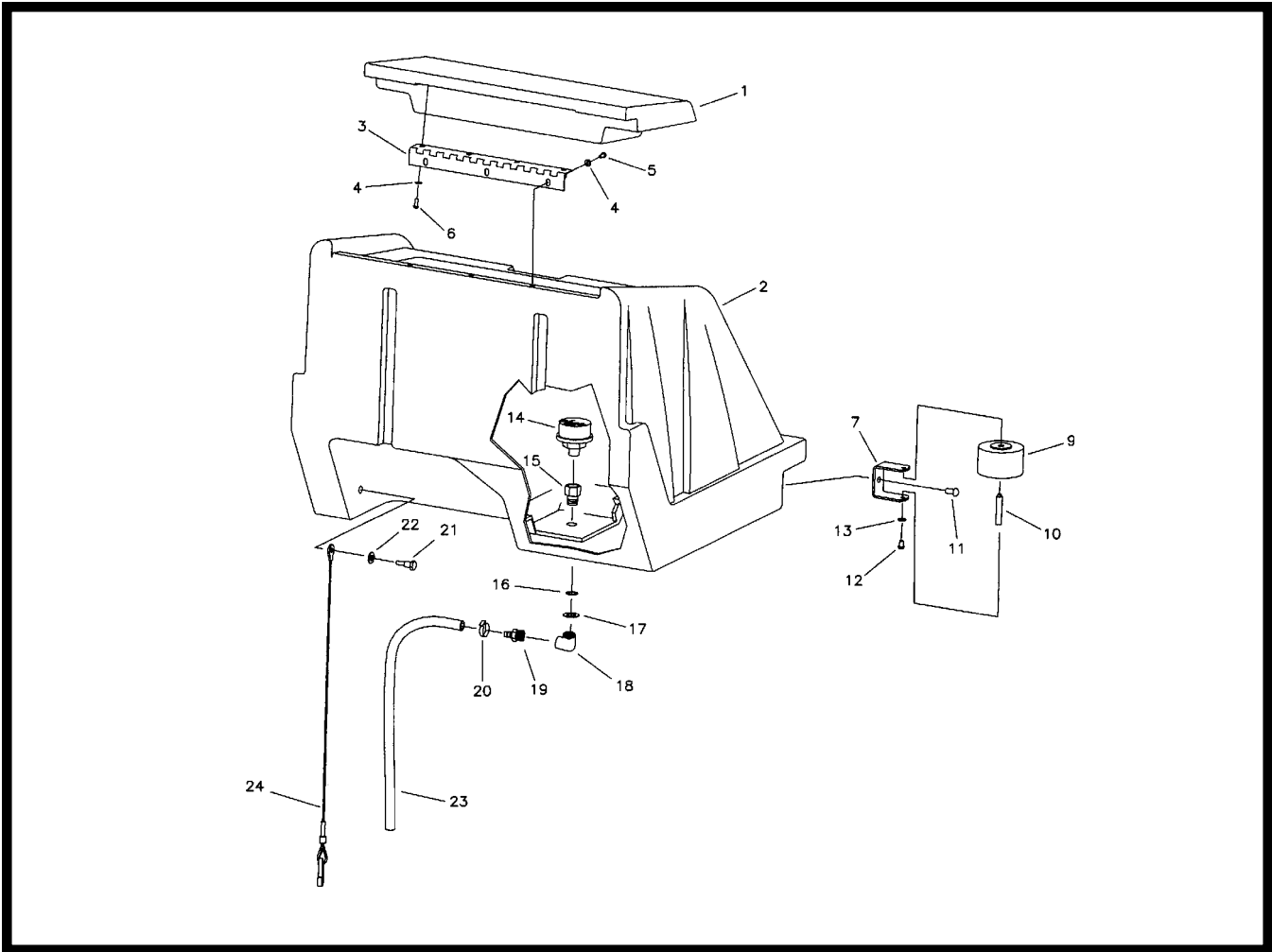

**320300  
SOLUTION TANK ASSEMBLY**

Item	Part No.	Qty.	Description
1	260029B	1	Solution Lid Burgundy
2	320120	1	Solution Tank
3	450021	1	Hinge
4	712764	7	WSR-SS #10
5			
6	712540	7	SCR-MC 10-24 x .37 SS TH
7	832949	2	Bracket - Bumper
8			
9	832896	2	Guide Wheel
10	833254	2	Bumper Wheel Axle
11	710985	2	SCR-SC 3/8-16 x .62
12	710353	2	SCR-MC 10-32 x .37
13	711553	2	WSR-Internal Lock 10
14	130118	1	Solution Strainer M3-40
15	210409	1	Adapter Brass 3/8 FPT x 3/8 MPT
16	210414	1	O-Ring
17	711513	1	WSR-Flat .69 x 1.06 x .03 SS
18	700028	1	90° Union EL 3/8 FPT x FPT 3/8
19	320265	1	3/8 Dubl-Barb x 3/8 MPT
20	450076	1	Crimp Clamp SS 185R
21	712575	1	5/16-18 x .75 HH SS
22	711506	1	WSR-Flat 5/16
23	320252	1	Hose, Nylon
24	210020	1	Solution Tank Cable Assembly

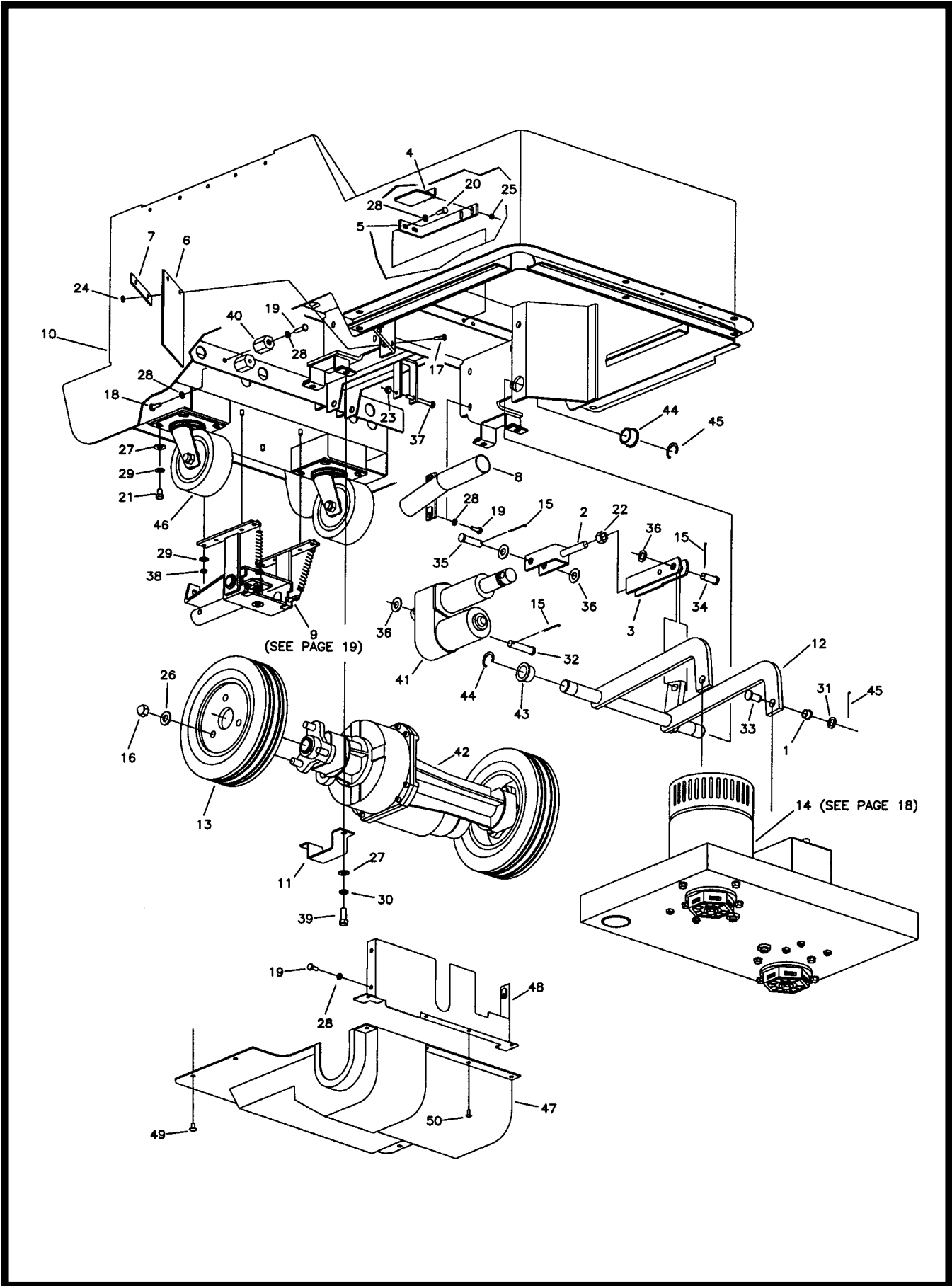

# Parts List

Item	Part No.	Qty.	Description
1	260041	2	½" Oilite Bushing
2	320140	1	Yoke Weldment
3	320148	1	Linkage Arm
4	320174	1	Switch Bracket
5	320175	1	Bracket Arm
6	320213	1	Splash Guard
7	320214	1	Retainer Strap
8	320236	1	Vacuum Pipe Weldment
9	320450	1	Squeegee Mech. Asm. Comp.
10	320700	1	Mainframe Weldment
11	320705	2	Transaxle Bracket, Lower
12	320707	1	Lift Weldment
13	320731	2	Wheel 10 x 2.75, 3 Bolt
14	320750	1	Scrubhead Assembly Complete
15	380-532-20	3	Cotter Key
16	670070	6	Acorn Nut ½-20
17	710180	2	SCR-MC ¼-20 x .75
18	711202	2	BLT-HH 1/4-20 x .50
19	711203	10	BLT-HH 1/4-20 x 5/8
20	711206	2	BLT-HH 1/4-20 x 3/4
21	711228	8	BLT-HH 5/16-18 x .75
22	711334	1	Nut-Hex ½-13
23	711373	1	Nut-Nyloc ¼-20
24	711425	2	Nut-Flanged Wizz ¼-20
25	711427	2	Nut-Flanged Wizz 10-24
26	711509	6	WSR-Flat ½
27	711515	12	WSR-Flat .38 x .82 x .05
28	711544	16	WSR-Helical ¼
29	711545	12	WSR-Helical 5/16
30	711546	4	WSR-Helical 3/8
31	711594	2	WSR-Flat .56 x .88 x .03
32	711669	1	Clevis Pin ½ x 2.25
33	711672	2	Clevis Pin ½ x 2
34	712108	1	Clevis Pin ½ x 1.25
35	712109	1	Clevis Pin ½ x 1.75
36	712310	4	WSR-Flat .52 x .87 x .06
37	712574	1	BLT-SS Carr ¼-20 x 3.00
38	712680	4	5/16-18 Nut SS
39	713042	4	BLT-HH 3/8-16 x 1.00 #5
40	740132	2	Insulator
41	740802	1	Actuator
42	744151	1	Transaxle 18" 36V
43	809236	2	1 Oilite Flanged Bushing
44	809237	2	Retaining Ring
45	809311	2	Cotter Pin
46	827110	2	Caster
47	320711	1	Transaxle Cover
48	320712	1	Splash Guard
49	710178	4	SCR-MC 1/4-20 x .50 STPL
50	712534	4	SCR-MC 10-24 x .50 SS

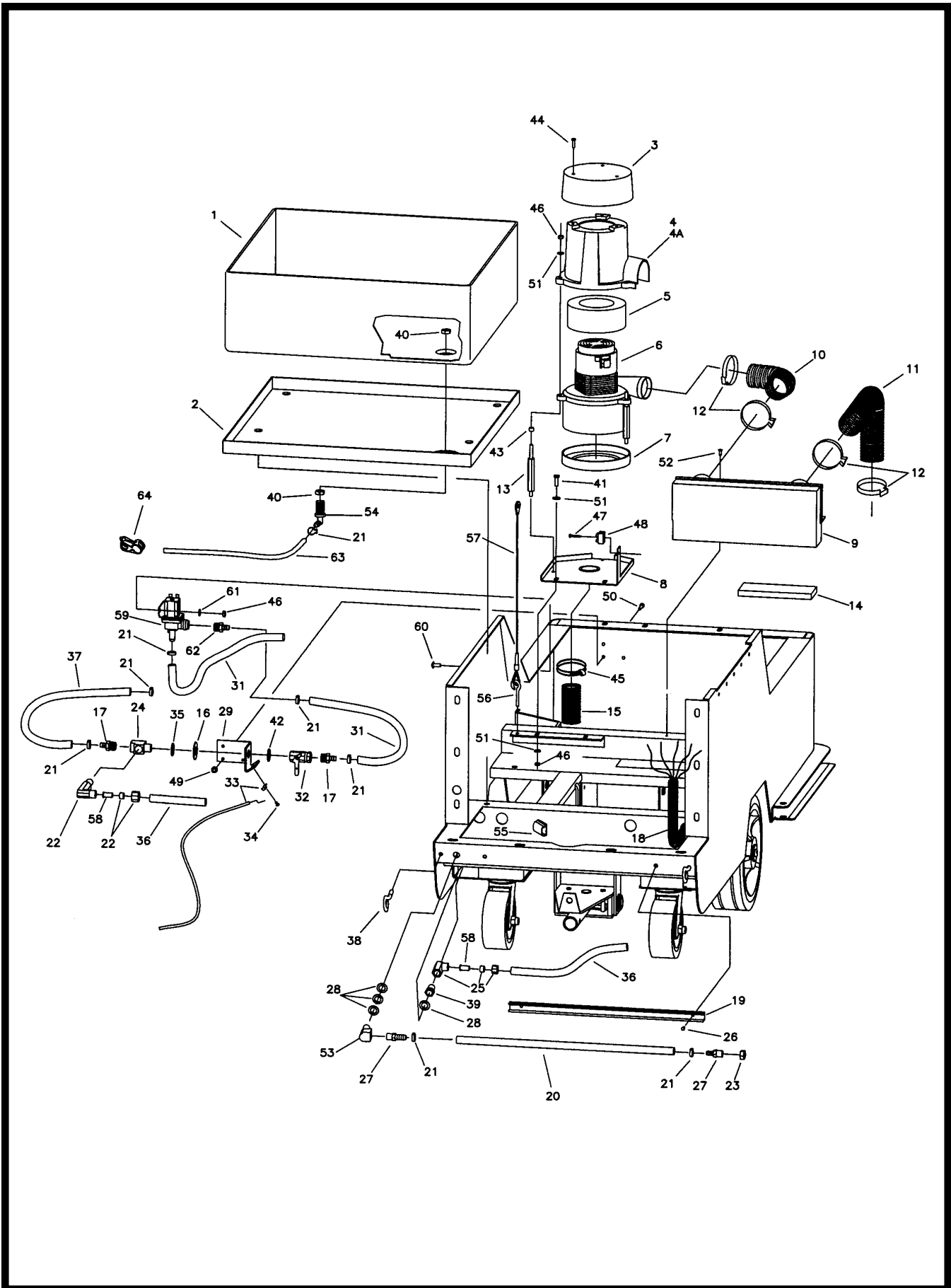

# Parts List

Item	Part No.	Qty.	Description
1	320215	1	Battery Tray Liner
2	320118	1	Battery Tray
3	840011	1	Vac Motor Cover, Top
4	840012	1	Vac Motor Cover, Bottom
4A	840012CTD	1	Vac Motor Cover, Bottom (CE)
5	380064	1	Foam Ring
6	740228	1	Vac Motor 36V 3-Stage
7	290017	1	Molded Gasket
8	320119	1	Motor Platform
9	320185	1	Exhaust Manifold Weldment
10	833191	1	Hose Rubber Flex 2 x 9
11	320216	1	Hose Rubber Flex 2 x 20
12	829067	4	Crimp Clamp
13	833265PLT	3	Stand-Off 1/4-20
14	809412	1	Gasket Support
15	320241	1	Vacuum Hose Short
16	828975	1	WSR-Neop .75 x 1.5 x .09
17	320265	2	3/8 DUBL-Barb x 3/8 MPT
18	742001	1	Wire Harness
19	430120	1	U-Channel
20	260181	1	Hose, Clear 18"
21	450076	9	Crimp Clamp SS 185R
22	420009	1	Hose Fitting (Male Elbow)
23	430114	1	Nylon Cap 1/4 FPT HC4
24	210408	1	3/8 Brass Tee
25	420065	1	Hose Fitting (Female Elbow)
26	711124	2	SCR-ST 10 x .38 NI
27	828952	3	3/8 Barb x 1/4 MPT
28	712760	4	WSR-Flat .56 x 1.00 SS
29	210370	1	Solution Valve Bracket
30			
31	320253	2	Valve Solution Hose
32	809413MCH	1	Solution Valve
33	210045	1	Solution Control Cable
34	711124	1	SCR-ST-B 10 x .37 NI
35	711512	1	WSR-Flat .75 x 1.37 x .08
36	320218	1	Clear Hose, Dump
37	320252	1	Wire Hose, Supply
38	712086	2	5/16 Wire Eyebolt
39	830708	1	Reducer 3/8 x 1/4
40	320272	2	Nut-PLS 1/4 NPT
41	712565	2	SCR-MC 1/4-20 x .63 SS
42	711517	1	WSR-Flat .77 x 1.37 X .03
43	762073	3	Spacer
44	711106	3	SCR-ST-A 10 x .75
45	260203	2	Hose Clamp Wire Grip
46	712667	7	Nut Nyloc 1/4-20 SS
47	711128	1	SCR-ST 8 x .63
48	832996	1	Terminal Block
49	712638	3	Nut-Hex 10-24 SS Nyloc
50	712537	3	SCR-MC 10-24 x .75 SS TH
51	711505	4	WSR-Flat 1/4
52	72-416-10	2	SCR-TF 1/4-20
53	831306	1	Street 90° 1/4 x 1/4
54	320271	1	90° Nozzle Fitting
55	809444	1	Clip Cord
56	712026	1	1/4 Wire Eyebolt
57	320246	1	Solution Tank Cable
58	420011	2	Sleeve Insert
59	740494	1	Water Valve 36VDC
60	712565	2	SCR-MC 1/4-20 x .62 SS
61	711504	2	WSR-Flat 1/4 ID SS
62	320264	1	3/8 DUBL-Barb x 1/4 MPF
63	260224	1	18" Hose
64	320273	1	Hose Shut-Off Clamp

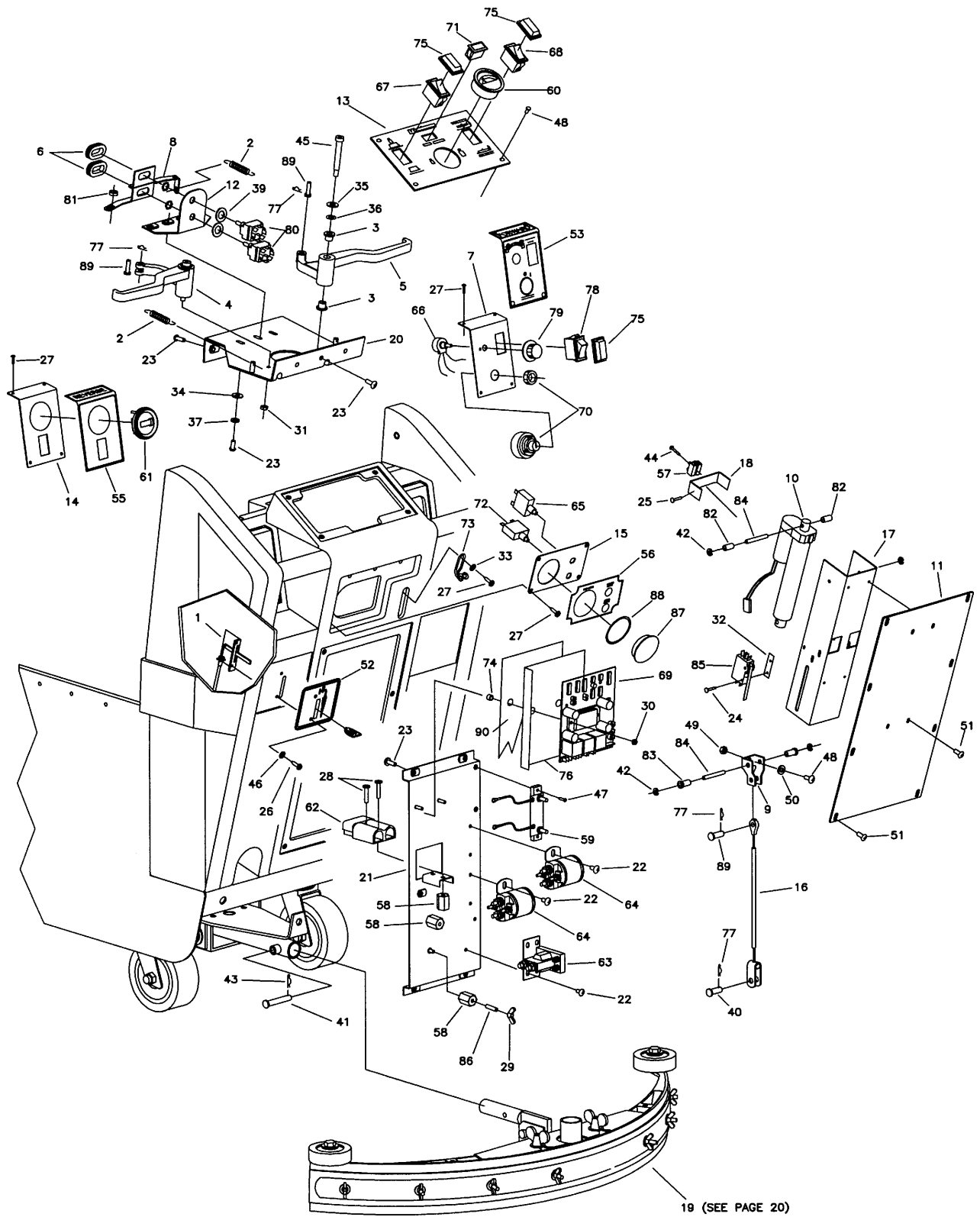



# Parts List

Item	Part No.	Qty.	Description	Item	Part No.	Qty.	Description
1	210045	1	Cable Solution Control	46	712320	2	WSR-Nylon .22 x .45 x .04
2	210413	2	Return Springs	47	712536	2	SCR-MC 10-24 x .62 STPL
3	260066	4	3/8 Oilite Flanged Bushing	48	712540	5	SCR-MC 10-24 x .37 TH
4	260069MCH	1	Left Handle	49	712638	1	Nut-Hex 10-24 SS Nyloc
5	260070MCH	1	Right Handle	50	712764	1	WSR-SS #10
6	260274	2	Rubber Grommet	51	712822	12	SCR-MC 10-24 x .50 TH
7	260255	1	Speed Control Bracket	52	715604	1	Decal Solution
7CE	260255CE	1	Speed Control Bracket, CE	53	715608	1	Forward Decal
8	320147	1	Switch Actuator Weldment	54			
9	320161	1	Clevis, Squeegee Cable	55	715611	1	Reverse Decal
10	320166	1	Linear Actuator - Squeegee	56	715617	1	Circuit Breaker Decal
11	320176	1	Back Panel	57	740036	1	Terminal Block, CE
12	320187	1	Dual Switch Bracket	58	740132	3	Insulator Glastic
13	320202CESP	1	Dashboard, CE Screen Printed	59	740134	1	Shunt
14	320203	1	Battery Gauge Bracket	60	740135	1	Meter, 100A DC - Pressure
15	320207	1	Circuit Breaker Face Plate	61	740136	1	Battery Condition
16	320211	1	Cable, Squeegee Cable	62	740147	1	Connector
17	320212	1	Actuator Support	63	740242	1	Contactors 36V
18	320247	1	Terminal Block Bracket, CE	64	740243	2	Solenoid 36V
19	320600	1	Squeegee Assembly Comp.	65	740247	1	30 amp Circuit Breaker
20	320706	1	Lever Mounting Bracket	66	740368	1	Potentiometer Assembly
21	320726	1	Electrical Panel	67	740800CE	1	Rocker Switch Momentary CE
22	710178	6	SCR-MC 1/4-20 x .50	68	740801CE	1	Rocker Switch CE
23	710180	15	SCR-MC 1/4-20 x .75	69	740803	1	Speed Control 36V
24	710207	2	SCR-MC 6-32 x 1.0	70	741005	1	Key Switch (optional)
25	711104	1	SCR-ST-A 10 x .50, CE	71	742010	1	Indicator Light, 36VDC
26	711125	2	SCR-ST-B 10 x .50	72	742266	1	60 amp Circuit Breaker
27	711161	14	SCR-Hi/Lo 10 x .75	73	760286	1	Wire Formed Hook
28	711210	1	Bolt-HH 1/4-20 x 1.25	74	200340	2	Spacer
29	711368	3	Wing Nut 1/4-20	75	740811	1	Switch Boot, CE
30	711372	2	Nut-Nyloc 8-32	76	805637	1	SCR Insulator
31	711420	2	Nut-Hex Jam 5/16-18	77	809311	4	Cotter Pin 7/64 x 1.0
32	711430	1	Tinnerman Clip	78	809754	1	Rocker Switch
33	711503	2	WSR-Flat 10	78A	740711CE	1	Rocker Switch, CE
34	711505	3	WSR-Flat 1/4	79	809874	1	Knob
35	711515	2	WSR-Flat .38 x .82 x .05	80	827060	2	Forward/Reverse Switches
36	711523	2	WSR-Wave .38 x .68 x .01	81	832015	2	Spacer
37	711544	3	WSR-Helical 1/4	82	833277PLT	2	Actuator Bush Plated
38	711575	1	WSR-Flat .312 x .75	83	833286PLT	2	Actuator Bush Plated
39	711579	2	WSR-Flat .56 x 1.00	84	833294	2	Actuator Pin
40	711668	1	Clevis Pin 3/8 x 1.0	85	833329	1	Micro Switch
41	711671	1	Clevis Pin .306 x 2.125	86	833638	3	Brass Stud
42	711720	4	Retaining Ring E Ext. .25	87	833823	1	2" Hole Plug
43	711808	1	Cotter Pin	88	833824	1	S.S. Washer 2 x 2.43 x .035
44	712088	1	SCR-Hi/Lo 8-18 x .75, CE	89	881002	3	Clevis Pin 5/16 x 1.00
45	712100	2	Bolt-Shoulder 3/8 x 2.25	90	260210	1	Moisture Guard for Item 69

# SCRUBHEAD ASSEMBLY 320750

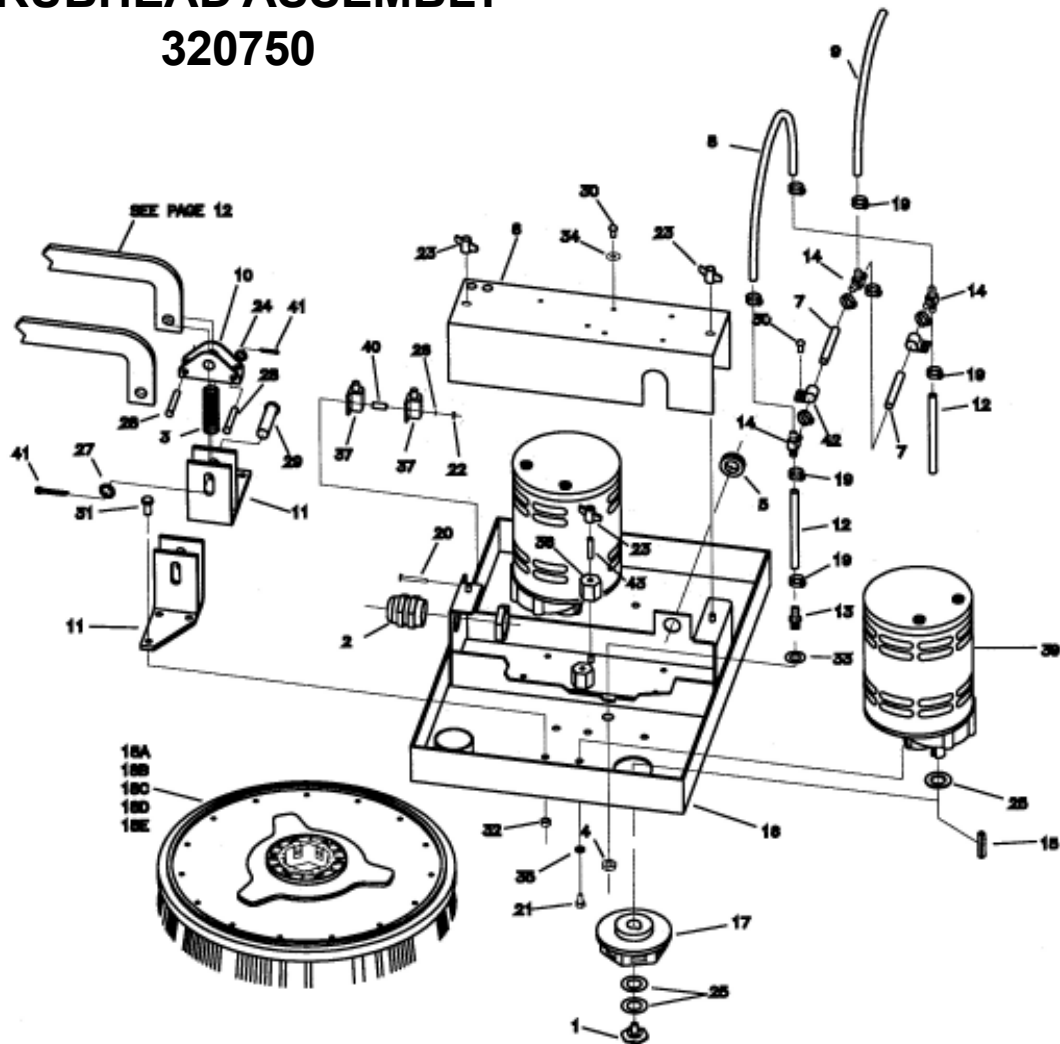

Item	Part No.	Qty.	Description	Item	Part No.	Qty.	Description
1	210066	2	Retainer Bolt	21	710986	8	SCR-SC 3/8-16 x 1.00 ST PL
2	210405	1	Liquid Tight Fitting	22	711304	2	Nut-Hex 8-32
3	260137	2	Compression Spring	23	711368	4	Wing Nut
4	260183	2	Nut-PLS 1/4 NPT	24	711506	4	WSR-Flat, 5/16 ST PL
5	260274	2	Rubber Grommet	25	711517	4	WSR-Flat .77
6	320173	1	Cover	26	711552	2	WSR-Internal Lock #8
7	320250	2	Short Solution Hose	27	711594	2	WSR-Flat .56 x .88 x .03
8	320251	1	By-Pass Hose	28	711671	4	Clevis Pin, .31 x 2.13
9	320253	1	Valve Solution Hose	29	711672	2	Clevis Pin, 1/2 x 2
10	320255	2	Bracket, Spring Support	30	712536	6	SCR-MC 10-24 x .63 SS
11	320258	2	Lift Bracket Weldment	31	712576	6	BLT-HH 5/16-18 x 1.25 SS
12	320259	2	Solution Hose	32	712683	6	Nut 5/16-18 SS Nyloc
13	320264	2	3/8 Dubl-Barb x 1/4 MPT	33	712760	2	WSR-Flat .56 x 1.06 x .04 SS
14	320266	3	3/8 Dubl-Barb Tee	34	712764	4	WSR-Flat 10 SS
15	320268	2	Key	35	712769	8	WSR-Helical 3/8 SS
16	320286	1	Motor Pan Weldment	36	740132	2	Insulator
17	430035	2	Drive Hub	37	740282	2	Switch
18A	430034	2	Nylon Brush	38	742121	1	Solenoid Wire Harness
18B	430108	2	Pad Driver	39	742714	2	Motor 36V 1HP
18C	430111	2	Poly-Grit Brush	40	761946	2	Spacer .196 x .312 x .75
18D	430131	2	Bassine Brush	41	809311	6	Cotter Pin
18E	430132	2	Strata-Grit Brush	42	827998	2	P-Clamp
19	450076	10	Crimp Clamp SS 185R	43	833638	2	Brass Stud
20	710036	2	SCR-MC 8-32 x 1.50				

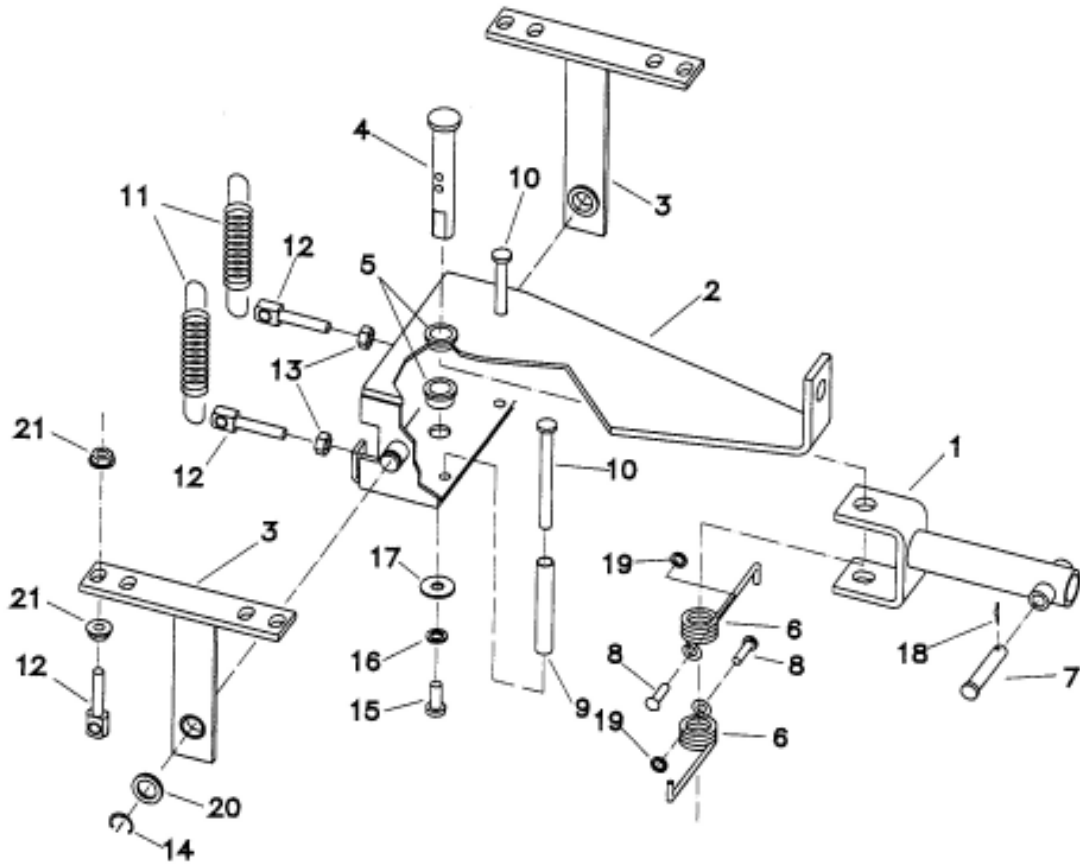

**320450  
SQUEEGEE MECHANISM  
ASSEMBLY**

Item	Part No.	Qty.	Description
1	320160	1	Yoke Weldment
2	320162	1	Spring Housing Weldment
3	320008	2	Pivot Bracket Weldment
4	210375	1	Swivel Pin
5	260041	2	1/2 Oilite Bushing
6	210391	2	Torsion Spring SS
7	711671	1	Clevis Pin 5/16 x 2.125
8	712536	2	SCR-MC 10-24 x .62
9	210400	2	Spacer Tube
10	710592	2	SCR-MC 1/4-20 x 2.75
11	430051	2	Return Spring
12	260292	4	Swing Bolt
13	712665	2	Nut-Hex 1/4-20
14	711715	2	3/4 Retaining Ring
15	712562	1	Bolt-HH 1/4-20 x .75 SS
16	712758	1	WSR-Helical 1/4 SS
17	711504	1	WSR-Flat .25 I.D. SS
18	711808	1	Cotter Pin
19	712320	2	WSR-Nylon .22 x .45 x .04
20	711517	2	WSR-Flat .75 x 1.375 x .09 SS
21	711425	4	Nut-Flange Whiz 1/4-20

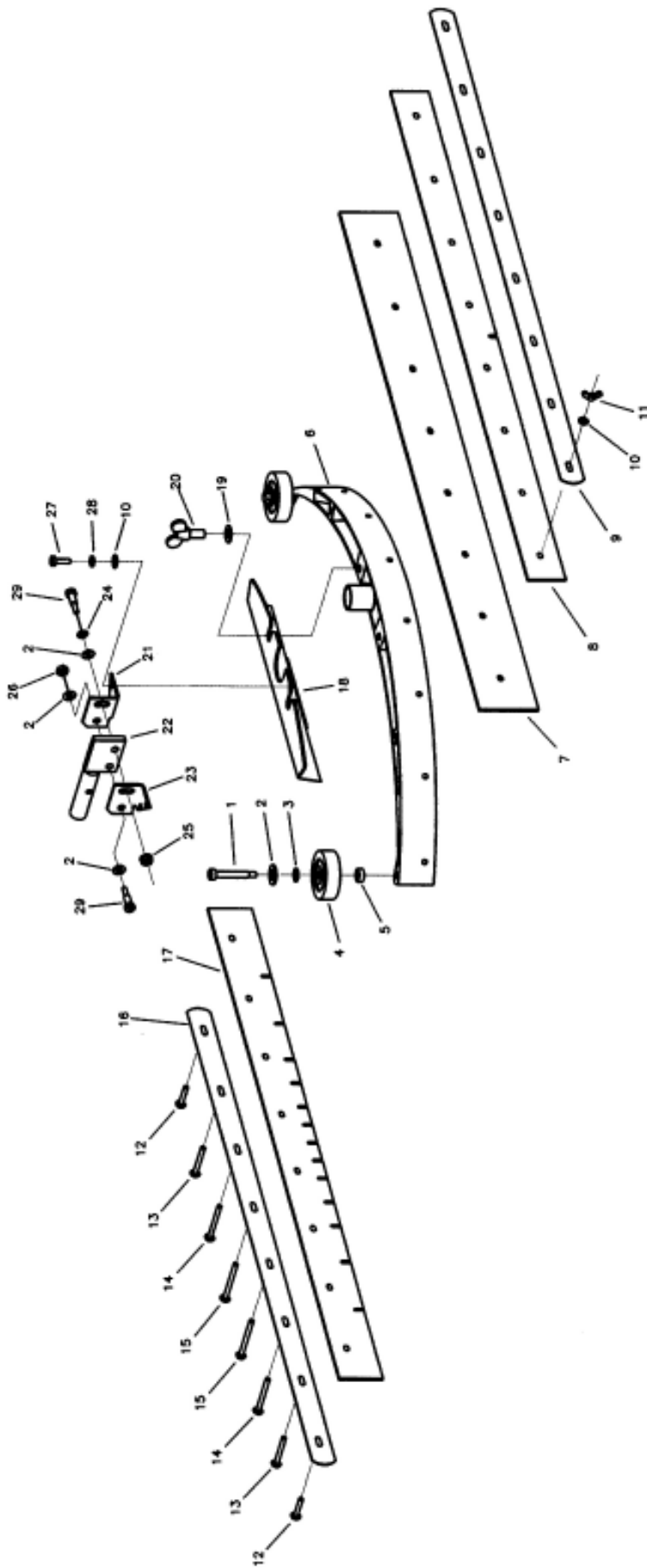

**320600 SQUEEGEE ASSEMBLY COMPLETE**

Item	Part No.	Qty.	Description	Item	Part No.	Qty.	Description
1	712091	2	Bolt-Shoulder 3/8 x 1.50	16	320193	1	Front Blade Strap
2	711507	5	WSR-Flat .37 x 1.12 x .06	17	320196	1	Front Squegee Blade
3	711592	2	WSR-Nylon .50 x 1.06 x .06	18	320191	1	Squegee Mounting Bracket
4	808829	2	Squegee Bumper Wheel	19	711578	2	WSR-Flat 1/2 Brass
5	832015	2	Spacer	20	220249	2	Wing-Bolt 1/2-13 x 1.00
6	320190MCH	1	Squegee Machined	21	320156	1	Mounting Bracket, Left
7	320194	1	Rear Squegee Blade	22	320154	1	Squegee Mount Weldment
8	320195	1	Reinforcement Blade	23	320157	1	Mounting Bracket, Right
9	320192	1	Rear Blade Strap	24	712301	1	WSR-Flat .37 x .87 x .07
10	711504	12	WSR-Flat .25 x .56 SS	25	711379	1	Nut-Flanged Wizz 5/16-18
11	712668	8	Wing Nut 1/4-20 SS	26	711374	1	Nut-Nyloc 5/16-18
12	712571	2	Bolt-SS Carr 1/4-20 x 1.50	27	712562	4	Bolt-HH 1/4-20 x .75 SS
13	712572	2	Bolt-SS Carr 1/4-20 x 2.00	28	712758	4	WSR-Helical 1/4 SS
14	712573	2	Bolt-SS Carr 1/4-20 x 2.50	29	712081	2	Bolt-Shoulder 3/8 x .75
15	712574	2	Bolt-SS Carr 1/4-20 x 3.00				

# WIRING DIAGRAM STANDARD MODEL

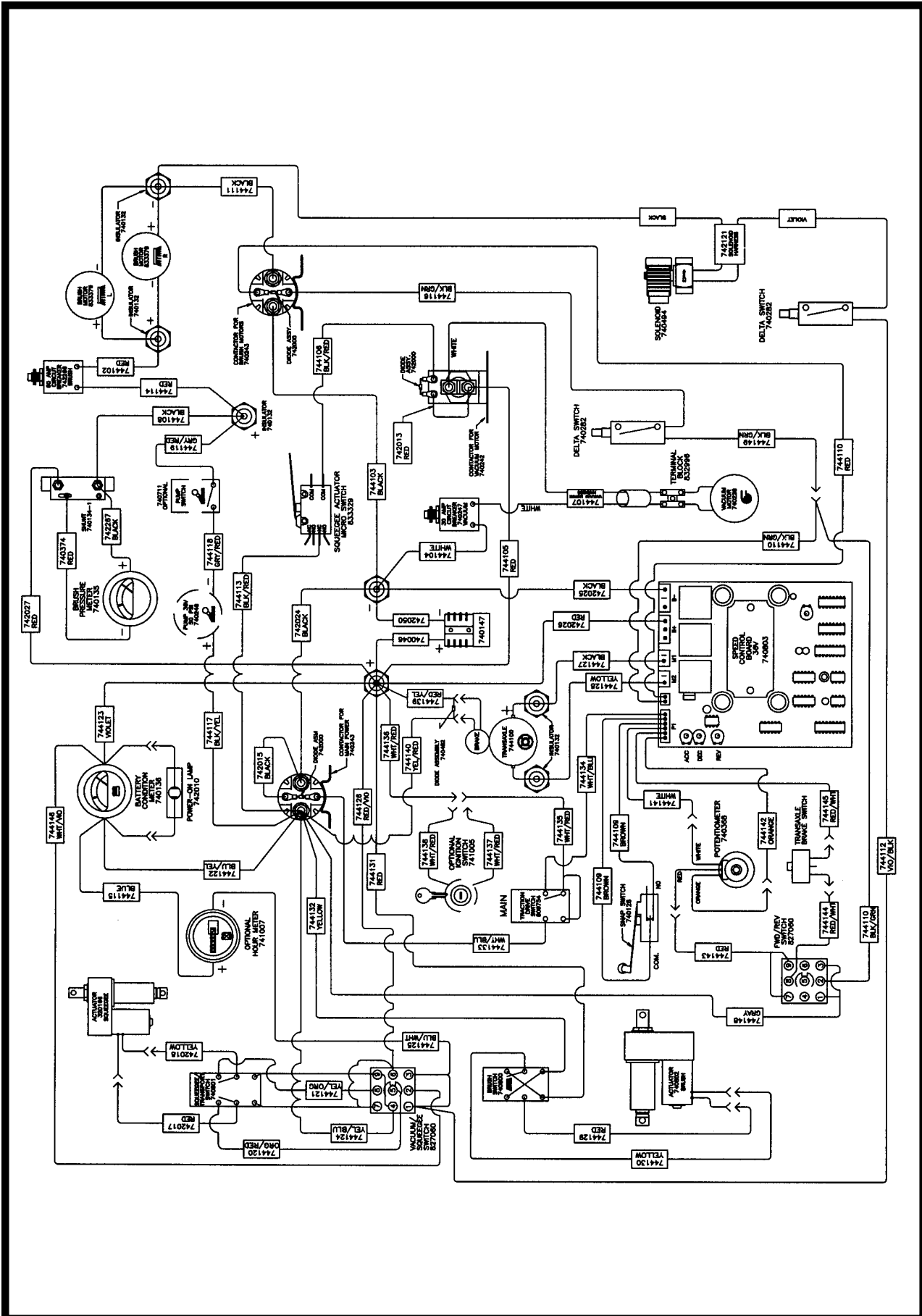

# WIRING DIAGRAM CE MODEL

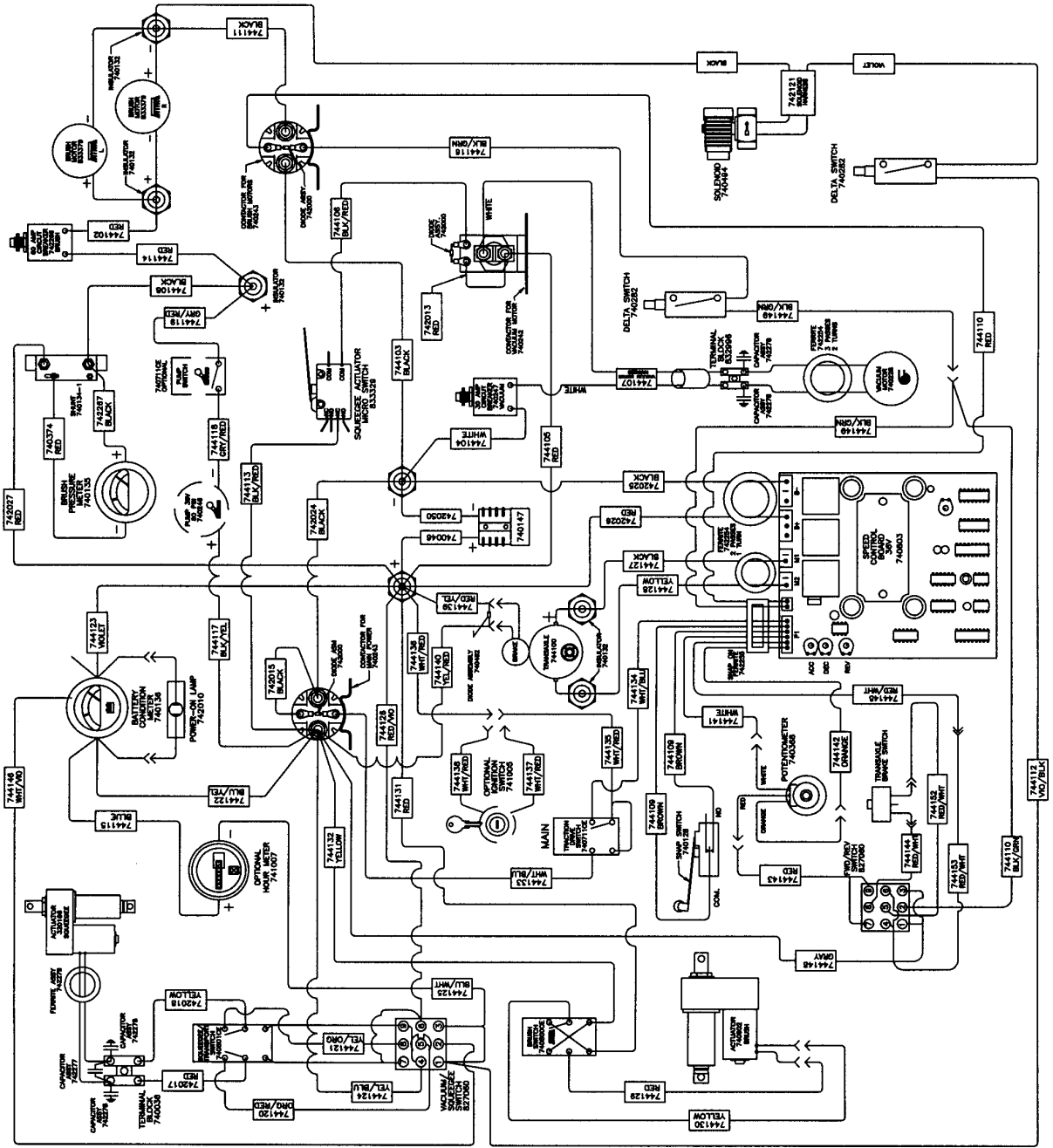

# LIMITED WARRANTY

Minuteman International, Inc. warrants to the original purchaser/user that this product is free from defects in workmanship and materials under normal use and service for a period of three years from date of purchase. In addition, Minuteman International, Inc. will, at its option, honor labor warranty claims for the first 12 months from date of sale, provided such claims are submitted through and approved by factory authorized repair stations. Minuteman International, Inc. will, at its option, repair or replace without charge, except for transportation costs, parts that fail under normal use and service when operated and maintained in accordance with the applicable operation and instruction manuals.

This warranty does not apply to normal wear, or to items whose life is dependent on their use and care, such as belts, cords, switches, hoses, rubber parts, electrical motor components or adjustments. Parts not manufactured by Minuteman International, Inc. such as engines, batteries, battery chargers, hydraulic pumps, and tires are covered by and subject to the warranties and/or guarantees of their manufacturers. Please contact Minuteman International, Inc. for procedures in warranty claims against these manufacturers.

**Special warning to purchaser** — Use of replacement filters and/or prefilters not manufactured by Minuteman International, Inc. or its designated licensees, will void all warranties expressed or implied.

A potential health hazard exists without exact original equipment replacement.

All warranted items become the sole property of Minuteman International, Inc. or its original manufacturer, whichever the case may be.

Minuteman International, Inc. disclaims any implied warranty, including the warranty of merchantability and the warranty of fitness for a particular purpose. Minuteman International, Inc. assumes no responsibility for any special, incidental or consequential damages.

This limited warranty is applicable only in the U.S.A. and Canada, and is extended only to the original user/purchaser of this product. Customers outside the U.S.A. and Canada should contact their local distributor for export warranty policies. Minuteman International, Inc. is not responsible for costs or repairs performed by persons other than those specifically authorized by Minuteman International, Inc. This warranty does not apply to damage from transportation, alterations by unauthorized persons, misuse or abuse of the equipment, use of non-compatible chemicals, or damage to property, or loss of income due to malfunctions of the product.

If a difficulty develops with this machine, you should contact the dealer from whom it was purchased.

This warranty gives you specific legal rights, and you may have other rights which vary from state to state. Some states do not allow the exclusion or limitation of special, incidental or consequential damages, or limitations on how long an implied warranty lasts, so the above exclusions and limitations may not apply to you.

## ***Minuteman***<sup>®</sup>

**World Headquarters**  
Minuteman International, Inc.  
111 South Rohlwing Road  
Addison, Illinois 60101

Minuteman Canada, Inc.  
2210 Drew Road  
Mississauga, Ontario  
L5S 1B1

(630) 627-6900  
FAX (630) 627-1130

(905) 673-3222  
FAX (905) 673-5161

988311  
Printed in U.S.A.

# 320 Floor Scrubber Traction Driven

Model: MC32036QP  
MC32036CE

OPERATION ■ SERVICE ■ PARTS ■ CARE

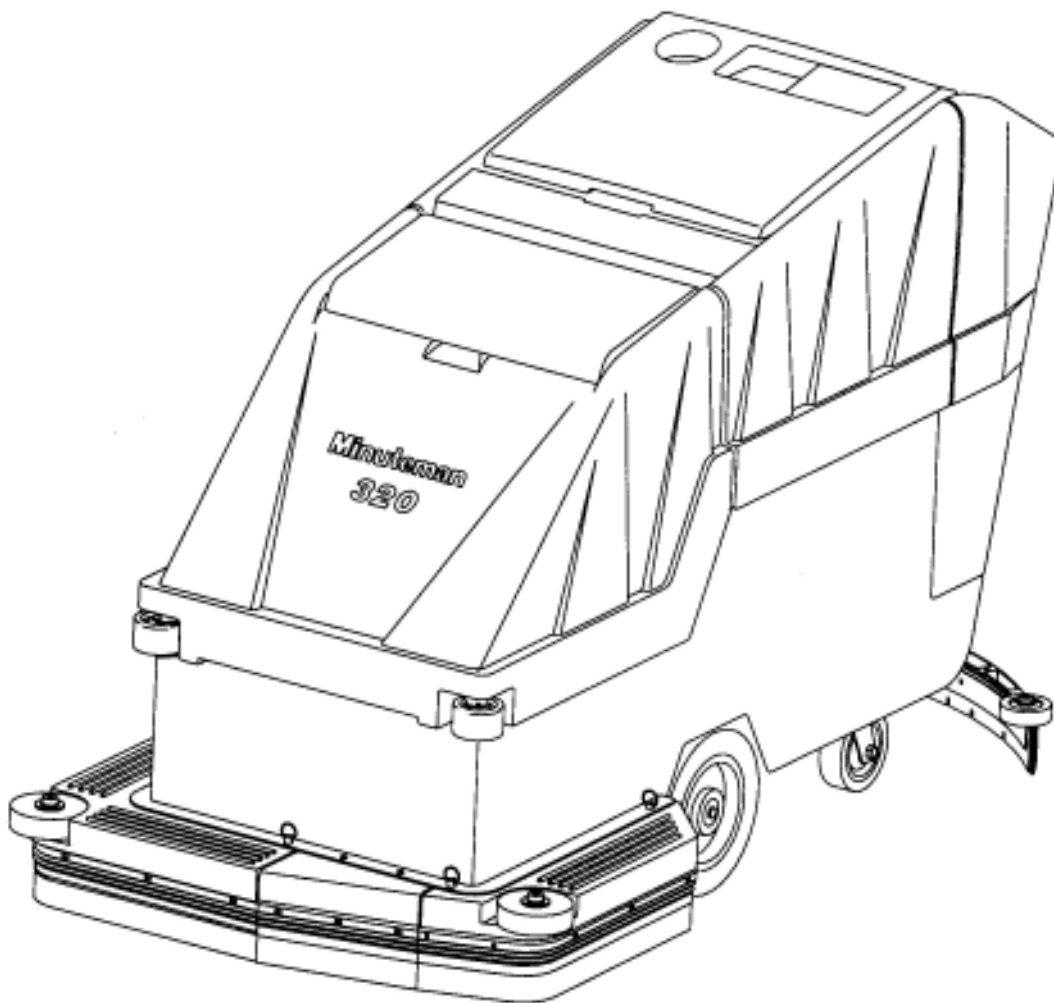



## EC Declaration of Conformity

according to Directives 89/392, 89/336 and 72/73

We, Minuteman International Incorporated, of 111 South Rohlwing Road Addison Illinois 60101 USA, declare under our sole responsibility that the product MC32036CE Commercial Automatic Floor Scrubbing machine to which this declaration relates corresponds to the relevant requirements of the EC Directives 89/392, 89/336 and 72/73. The following standards were used to determine compliance with the Directives: EN 292, EN 294, EN 811, EN 55011, EN 55104, EN 50082-2, EN 60335-1 and IEC 335-2-72 .

SOUND		VIBRATION						
<b>72 dB Operator</b>	<b>69 dB At 3m</b>	<b>1.9 m/s<sup>2</sup> At Operators Hand Grips</b>						
Tests were conducted on 6/7/96 with calibrated sound and vibration equipment under the conditions noted below: <table style="width: 100%; margin-top: 10px;"> <tr> <td style="width: 50%;">General Condition: Cloudy</td> <td style="width: 50%;">Wind: 0 km/hr</td> </tr> <tr> <td>Temperature: 29°C</td> <td>Humidity: 85%</td> </tr> <tr> <td>Barometric Pressure: 29.5</td> <td></td> </tr> </table>			General Condition: Cloudy	Wind: 0 km/hr	Temperature: 29°C	Humidity: 85%	Barometric Pressure: 29.5	
General Condition: Cloudy	Wind: 0 km/hr							
Temperature: 29°C	Humidity: 85%							
Barometric Pressure: 29.5								

  
 \_\_\_\_\_  
 Kenneth Kaczmarz, Standards Engineer

12/19/97  
 \_\_\_\_\_  
 Date

## TABLE OF CONTENTS

	<b>Page</b>
Safety Instructions	1
Electrical Requirements	2
Control Panel Identification	3
Squeegee Adjustments	4
Operating Instructions	5
Maintenance of Machine	6 & 7
Main Polyethylene Components	8 & 9
Recovery Tank	10
Solution Tank	11
Drive Assemblies	12 & 13
Main Frame	14 & 15
Console Assembly	16 & 17
Scrubhead Assembly	18
Squeegee Mechanism Assembly	19
Squeegee Assembly Complete	20
Wiring Diagram Standard Model	21
Wiring Diagram CE Model	22